

LAMP REPLACEMENT LED CLUSTER P19 series

Features:

- Easy Installation uses existing socket.
- Maintenance free. Operating life up to 100,000 hours.
- Energy saving. Low Power consumption.
- Solid state fast turn on. No power surge
- Low heat generation.
- Vibration resistant
- Custom design available



• Part selection and electro-optical Characteristics (ratings @ Ta = 25°C)

PART NO	COLOUR		Wavelength λ_{Dnm}	No. Of LED lamps	Power Watts (W)	luminous intensity (cd)	viewing angle $2\theta_{1/2}$ (deg)
	Emitted	Lens					
P19S-xxx01R	Red	Smooth	660	19	2	50	30
P19R-xxx01R	Red	Rough	660	19	2	40	45
P19S-xxx01YS	Yellow	Smooth	587	19	2	60	30
P19R-xxx01YS	Yellow	Rough	587	19	2	50	45
P19S-xxx01G	Green	Smooth	525	19	2	60	30
P19R-xxx01G	Green	Rough	525	19	2	50	45
P19S-xxx01B	Blue	Smooth	470	19	2	50	30
P19R-xxx01B	Blue	Rough	470	19	2	40	45
P19S-xxx01W	White	Smooth	X=0.28~0.32 y=0.27~0.33	19	2	50	30
P19R-xxx01W	White	Rough		19	2	40	45

• Note: xxx denotes fitting B22 Bayonet or E27 Screw Cap

Package Dimensions

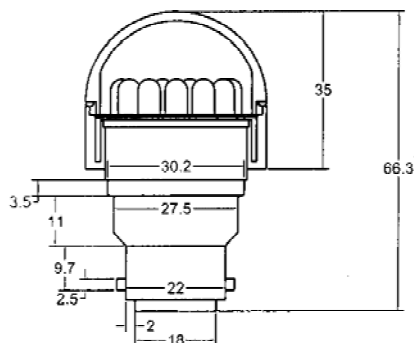

B22 Bayonet Cap

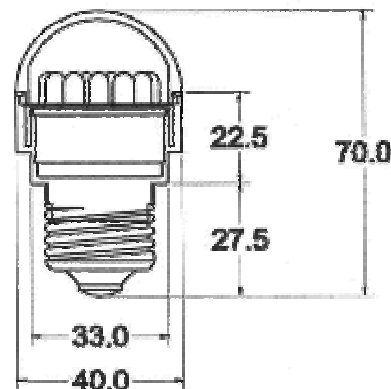

E27 Screw cap

Specifications may be subject to change without notice.