

## 1W LED Recessed Marker Light

## LDR-35C series

### Dimensions

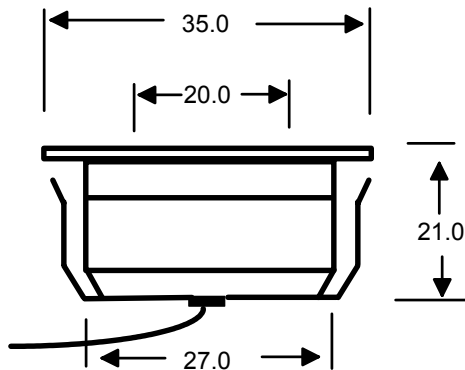

### Description

The LDR-35C series 1W recessed luminaires comprise of a 35mm dia. bezel and 20mm dia. illumination area. Constructed from High performance grade 316 Stainless Steel a choice of three lens types are available. The fitting is encapsulated maintaining mechanical integrity and offering ingress protection to IP 65. Termination is provided by a 10 metre lead fitted with a 1.3mm DC plug to facilitate easy connection. Must be used in conjunction with constant current LED drivers. Multiple units can be configured using the LD Splitter box.

### Optical Characteristics

Colour	Wavelength	Intensity typ. (lm)
Red	625 nm	35
Amber	590 nm	35
Red/Orange	615 nm	35
Green	525 nm	30
Blue	470 nm	8
White	7000 K	30
Warm White	3325 K	30

### Electrical Parameters

Power Consumption	1W
Maximum Current	350mA

### Part No

Part No	Description	Angle
LDR-35C-F-x	Flood	22°
LDR-35C-S-x	Spot	10°
LDR-35C-R-x	Reflector	40°

### Electronic Transformers - Constant Current

Part No	Input Voltage	Output	Drive
PSU-LD1W-2	100 ~ 240v ac	350mA	2x 1W
PSU-LD1W-6	100 ~ 240v ac	350mA	6x 1W
PSU-LD1W-12	100 ~ 240v ac	350mA	12x1W
LD-Splitter box	Facilitates plug in connection of 1 to 6 units		

These fittings must not be connected directly to fixed voltage supplies and must be used in conjunction with constant current drivers. Specifications may be subject to change without notice.

## LED Groundlight Kit Instructions

### Model LDR-35C

Please refer to these instructions prior to installation and retain for future reference  
If in doubt we recommend that you refer to a qualified electrician.

#### Specification

LED Driver: Constant current Electronic Transformers.

Input: 100 ~ 240v ac 50~60Hz

	<b>Part No.</b>		
Output:	PSU-LD1W-2	350mA	2x 1W
	PSU-LD1W-6	350mA	6x 1W
	PSU-LD1W-12	350mA	12x 1W

Use LED splitter box to configure multiple units in series

#### LED 6 way Splitter Box S7



#### Installation:

Check clearance below surface to avoid pipes or cables etc.

Ensure that the fittings are in a position to allow the connecting lead to reach the transformer or splitter.

Cut Holes  $\varnothing$  36mm on the installation surface

Push LED fittings into holes

Insert the DC plugs from the LED fittings into the splitter box

Connect the driver to mains supply to test the system.

#### Safety:

The fitting is designed to operate at a safe, low voltage for use with the constant current driver supplied.

Do not connect any other electrical appliance or driver to this lighting kit or make any modifications.

Any modification will invalidate the product warranty.

If any part of the fitting is damaged it should be replaced by the manufacturer or service agency.

#### Warnings:

The fittings should be used in conjunction with the LD series of drivers

Failure to match the LED fittings with a compatible driver may result in reduced life or erratic operation

High ambient temperature may damage LED performance

Ensure that any connection to the mains supply is cut off prior to installation.

The product enclosed may vary slightly from the illustration